

RPC-2.92 Adaptor  
RPC-2.40 Plug - Plug

**02S109-S0BS3**

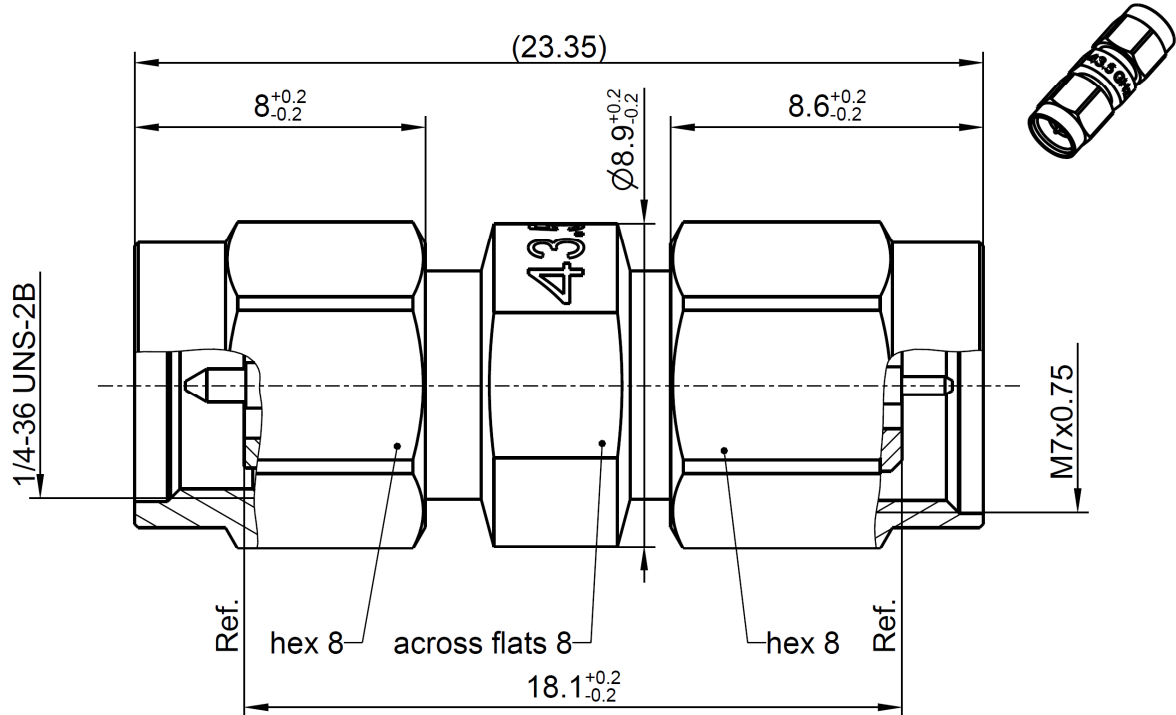

All dimensions are in mm

**Interface**

RPC-2.92 according to	IEC 61169-35
RPC-2.92 mechanically compatible with	RPC-3.50 and SMA
RPC-2.40 according to	IEC 61169-40
RPC-2.40 mechanically compatible with	RPC-1.85

**Documents**

N/A

**Material and plating**

**Connector parts**

Center contact  
Outer contact  
Coupling nut  
Dielectric

**Material**

CuBe  
Stainless steel  
Stainless steel  
TPX

**Plating**

Gold, min. 1.27  $\mu$ m, over chemical nickel  
Passivated  
Passivated

RPC-2.92 Adaptor  
 RPC-2.40 Plug - Plug

**02S109-S0BS3**

**Electrical data**

Impedance 50 Ω  
 Frequency DC to 43.5 GHz  
 Return loss ≥ 28 dB, DC to 12 GHz  
 ≥ 25 dB, 12 GHz to 26.5 GHz  
 ≥ 18 dB, 26.5 GHz to 43.5 GHz  
 Insertion loss ≤ 0.05 x √f(GHz) dB  
 Insulation resistance ≥ 5 GΩ  
 Test voltage 500 V rms  
 Working voltage 150 V rms  
 RF-leakage ≥ 100 dB up to 1 GHz

**Mechanical data**

Mating cycles ≥ 500  
 Center contact captivation ≥ 20 N  
 Coupling test torque RPC-2.92 1.70 Nm  
 Recommended torque RPC-2.92 0.80 Nm to 1.10 Nm  
 Coupling test torque RPC-2.40 1.65 Nm  
 Recommended torque RPC-2.40 0.80 Nm to 1.10 Nm

**Environmental data**

Temperature range -40°C to +125°C  
 Thermal shock MIL-STD-202, Method 107, Condition B  
 Corrosion MIL-STD-202, Method 101, Condition B  
 Vibration MIL-STD-202, Method 204, Condition D  
 Shock MIL-STD-202, Method 213, Condition I  
 Moisture resistance MIL-STD-202, Method 106  
 RoHS compliant

**Tooling**

N/A

**Suitable cables**

N/A

**Weight**

6.5 g/pce

While the information has been carefully compiled to the best of our knowledge, nothing is intended as representation or warranty on our part and no statement herein shall be construed as recommendation to infringe existing patents. In the effort to improve our products, we reserve the right to make changes judged to be necessary.

Draft	Date	Approved	Date	Rev.	Engineering change number	Name	Date
S. Andorfer	09.07.20	H. Babinger	30.07.24	a00	24-s209	M. Knoll	30.07.24
Rosenberger Hochfrequenztechnik GmbH & Co. KG P.O.Box 1260 D-84526 Tittmoning Germany <a href="http://www.rosenberger.de">www.rosenberger.de</a>					Tel.: +49 8684 18-0 Email: <a href="mailto:info@rosenberger.de">info@rosenberger.de</a>		Page 2 / 2